



GS1532 to GS1528 Interface

Reference Design

Revision History

Version	ECR	Date	Changes and/or Modifications
3	153754	September 2009	Updated to latest Gennum template.
2	137607	July 2005	Added 4u7 capacitors to output BNC connectors in schematic
1	135367	January 2005	Change RSET from 281 Ω to 187 Ω to produce 800mV across 50 Ω loads.
0	131650	September 2003	New document.

1. Description

This document serves as a design guide for interfacing Gennum's GS1532 serializer to the GS1528 cable driver. It is recommended that the GS1528 be used to achieve best performance at HD data rates. Multiple cable drivers may be added as necessary.

Figure 1-1 shows the interface between the GS1532 and two GS1528s. The upper GS1528 uses one active output with the 2nd output terminated using a 75Ω 'dummy' load. The other GS1528 has both outputs active.

Figure 1-2 shows the recommended PCB layout for a single GS1528 fed from the GS1532. Shading indicates power and ground plane voids. The cable driver should be placed close to the BNC. The termination resistors should be kept close to the input pins as shown.

For further information, please contact Gennum's Video Transport Product Applications Engineering group.

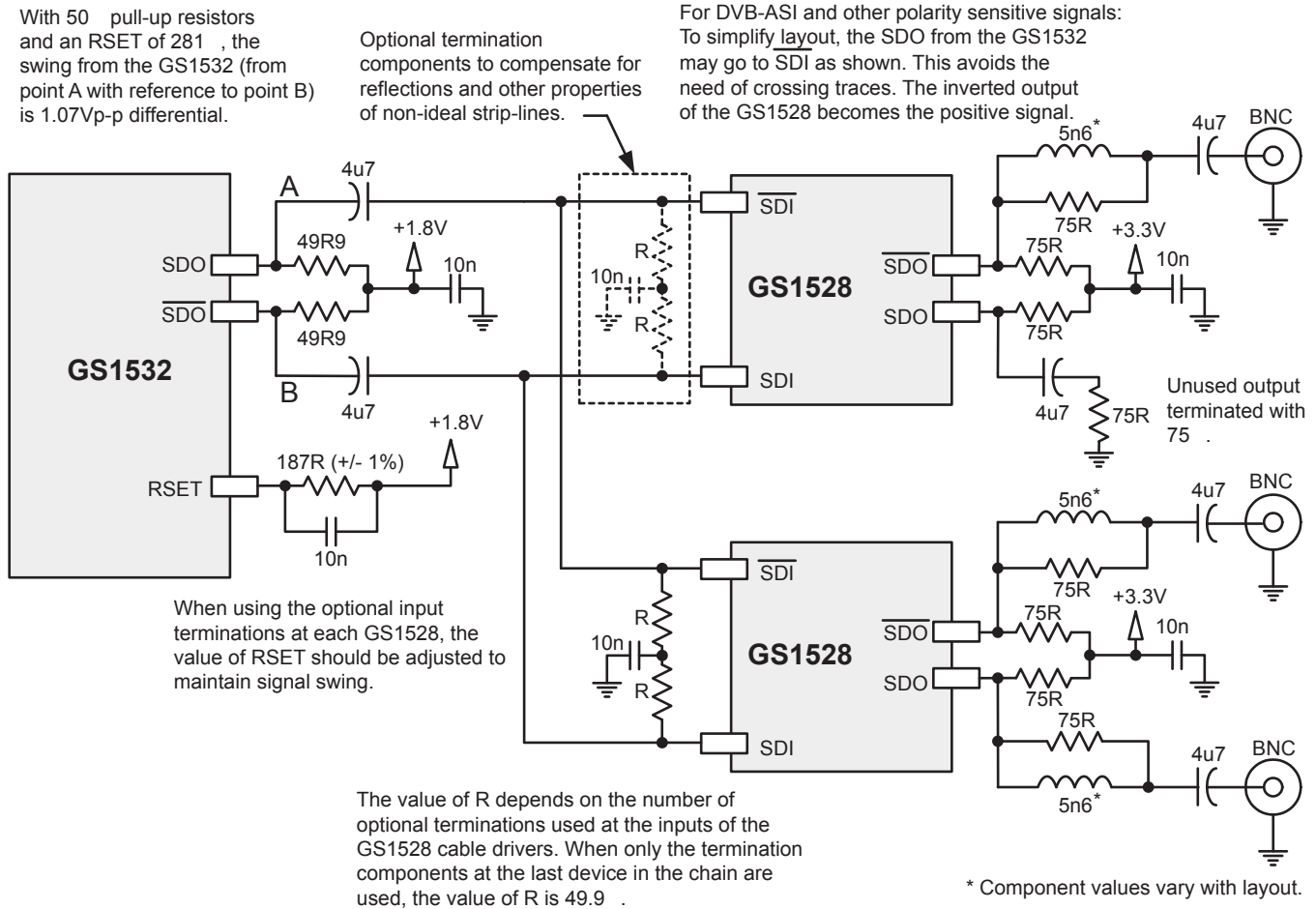

Figure 1-1: Interface between the GS1532 and two GS1528s

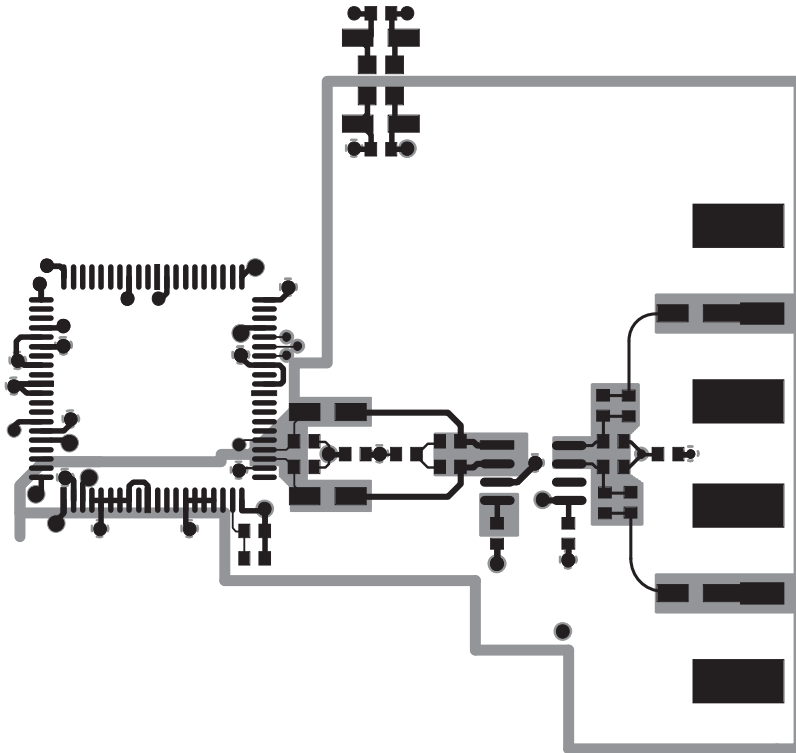

Figure 1-2: Recommended PCB layout for a single GS1528 fed from a GS1532

**DOCUMENT IDENTIFICATION
REFERENCE DESIGN**

Information relating to this product and the application or design described herein is believed to be reliable, however such information is provided as a guide only and Gennum assumes no liability for any errors in this document, or for the application or design described herein. Gennum reserves the right to make changes to the product or this document at any time without notice.

CAUTION

ELECTROSTATIC SENSITIVE DEVICES
DO NOT OPEN PACKAGES OR HANDLE EXCEPT AT A
STATIC-FREE WORKSTATION



GENNUM CORPORATE HEADQUARTERS

4281 Harvester Road, Burlington, Ontario L7L 5M4 Canada

Phone: +1 (905) 632-2996

E-mail: corporate@gennum.com

Fax: +1 (905) 632-2055

www.gennum.com

OTTAWA

232 Herzberg Road, Suite 101
Kanata, Ontario K2K 2A1
Canada

Phone: +1 (613) 270-0458

Fax: +1 (613) 270-0429

CALGARY

3553 - 31st St. N.W., Suite 210
Calgary, Alberta T2L 2K7
Canada

Phone: +1 (403) 284-2672

UNITED KINGDOM

North Building, Walden Court
Parsonage Lane,
Bishop's Stortford Hertfordshire, CM23 5DB
United Kingdom

Phone: +44 1279 714170

Fax: +44 1279 714171

INDIA

#208(A), Nirmala Plaza,
Airport Road, Forest Park Square
Bhubaneswar 751009
India

Phone: +91 (674) 653-4815

Fax: +91 (674) 259-5733

SNOWBUSH IP - A DIVISION OF GENNUM

439 University Ave. Suite 1700
Toronto, Ontario M5G 1Y8
Canada

Phone: +1 (416) 925-5643

Fax: +1 (416) 925-0581

E-mail: sales@snowbush.com

Web Site: <http://www.snowbush.com>

MEXICO

288-A Paseo de Maravillas
Jesus Ma., Aguascalientes
Mexico 20900

Phone: +1 (416) 848-0328

JAPAN KK

Shinjuku Green Tower Building 27F
6-14-1, Nishi Shinjuku
Shinjuku-ku, Tokyo, 160-0023
Japan

Phone: +81 (03) 3349-5501

Fax: +81 (03) 3349-5505

E-mail: gennum-japan@gennum.com

Web Site: <http://www.gennum.co.jp>

TAIWAN

6F-4, No.51, Sec.2, Keelung Rd.
Sinyi District, Taipei City 11502
Taiwan R.O.C.

Phone: (886) 2-8732-8879

Fax: (886) 2-8732-8870

E-mail: gennum-taiwan@gennum.com

GERMANY

Hainbuchenstraße 2
80935 Muenchen (Munich), Germany

Phone: +49-89-35831696

Fax: +49-89-35804653

E-mail: gennum-germany@gennum.com

NORTH AMERICA WESTERN REGION

691 South Milpitas Blvd., Suite #200
Milpitas, CA 95035
United States

Phone: +1 (408) 934-1301

Fax: +1 (408) 934-1029

E-mail: naw_sales@gennum.com

NORTH AMERICA EASTERN REGION

4281 Harvester Road
Burlington, Ontario L7L 5M4
Canada

Phone: +1 (905) 632-2996

Fax: +1 (905) 632-2055

E-mail: nae_sales@gennum.com

KOREA

8F Jinnex Lakeview Bldg.
65-2, Bangidong, Songpagu
Seoul, Korea 138-828

Phone: +82-2-414-2991

Fax: +82-2-414-2998

E-mail: gennum-korea@gennum.com

Gennum Corporation assumes no liability for any errors or omissions in this document, or for the use of the circuits or devices described herein. The sale of the circuit or device described herein does not imply any patent license, and Gennum makes no representation that the circuit or device is free from patent infringement.

All other trademarks mentioned are the properties of their respective owners.

GENNUM and the Gennum logo are registered trademarks of Gennum Corporation.

© Copyright 2005 Gennum Corporation. All rights reserved.

www.gennum.com