



GV7601 Avia™ Receiver

Key Features

- Serial digital video receiver for standard and high definition component video:
 - SD 525i and 625i
 - HD 720p 24, 25, 30, 50 and 60
 - HD 1080i 50, 60
 - HD 1080p 24, 25, 30, 50 and 60
- Supports 8-bit, 10-bit or 12-bit component digital video:
 - RGB or YCbCr 4:4:4 sampled
 - YCbCr 4:2:2 or 4:2:0 sampled
- Integrated cable equalizer for long reach cable performance
 - 230m typical HD performance over high performance 75Ω coaxial cable (Belden 1694A or equivalent)
 - 160m typical HD performance over RGS9 or equivalent 75Ω coaxial cable
- Serial digital loop-through output
- Integrated audio de-embedder for the extraction of up to 8 channels of 48kHz digital audio
- Supports IEC 13818-1 compliant transport streams over the Asynchronous Serial Interface (ASI)
- Automatic selection between SD/HD component video and ASI input data
- Ancillary (ANC) data detection and extraction
- User selectable processing features, including:
 - Timing Reference Signal (TRS) error detection and correction
 - ANC data checksum error detection and correction
 - Programmable ANC data detection
 - Line number and CRC error detection and correction
 - Illegal video code word re-mapping
- 4-wire Gennum Serial Peripheral Interface (GSPI) for external host command and control
- JTAG test interface
- 1.2V core and 3.3V analog voltage power supplies
- 1.8V or 3.3V selectable digital I/O power supply
- Small footprint 100-BGA (11mm x 11mm)
- Low power operation, typically 570mW at HD
- Pb-free and RoHS compliant

Applications

- Digital video recorders (DVR)
- Video servers
- Video mixers and switchers
- Image capture devices
- Video framegrabbers
- Camcorders
- Video monitors & displays

Description

The GV7601 is a serial digital video receiver for standard and high definition component video, operating at 270Mb/s, 1.485Gb/s and 2.97Gb/s data rates. With integrated cable equalizer technology, the GV7601 is capable of receiving digital video over 75Ω coaxial cable at lengths up to 460m for standard definition video, and up to 230m for high definition. This provides a complete receive solution for the transmission of both interlaced and progressive component digital video, up to 1920 x 1080, in coaxial cable-based video systems.

Using the GV7601 with the complete Avia™ receiver reference design, it is possible to implement an all-digital, bi-directional multimedia interface over coax. This interface allows both DC power and a bi-directional, half-duplex, auxiliary data interface to be carried over the same single, robust and cost effective coaxial cable as the high-speed serial digital video. The GV7601 also provides a re-timed serial digital output for video loop-through applications.

The GV7601 includes a broad range of user-selectable processing features, such as Timing Reference Signal (TRS) error detection and extraction, illegal code word re-mapping, and ancillary data packet extraction. The content of ancillary data packets, embedded by an Avia transmitter, can be extracted and retrieved via the host interface. Device configuration and status reporting is accomplished via the Gennum Serial Peripheral Interface (GSPI). Alternatively, many processing features and

operational modes can be configured directly through external pin settings.

The device can output both 8-bit, 10-bit and 12-bit video data, for RGB or YCbCr 4:4:4, and YCbCr 4:2:2 or 4:2:0. A configurable 20-bit wide parallel digital video output bus is provided, with associated pixel clock and timing signal outputs. The GV7601 supports ITU-R BT.656 SD formats, and HD formats conforming to ITU-R BT.709 and BT.1120-6 for 1125-line formats, and SMPTE 296M for 750-line formats. The device may also be configured to output CEA-861 timing.

The GV7601 audio de-embedding function allows the up to 8 channels of serial digital audio within the ancillary data space of the video data stream to be extracted. The audio output signal formats supported by the device include AES/EBU for professional applications, S/PDIF, and I²S. 16-bit, 20-bit and 24-bit audio formats are supported at 48kHz synchronous-to-video for SD video formats and

48kHz synchronous or asynchronous for HD formats. Additional audio processing features include: individual channel extraction, audio group selection, group replacement, channel swapping and audio channel status extraction.

The GV7601 also supports an Asynchronous Serial Interface (ASI) 270Mb/s input, carrying compressed audio and video transport streams, conforming to IEC 13818-1. Transport stream data is output from the device at a synchronous 27MHz clock rate. The device will automatically deserialize and 8b/10b decode the data.

Packaged in a space saving 100-BGA, the GV7601 is ideal for designs where high-density component placement is required. Typically requiring only 600mW power, the device can be used as a high bandwidth alternative to analog composite or component video interfaces, providing a high quality, all-digital, long reach video receive solution.

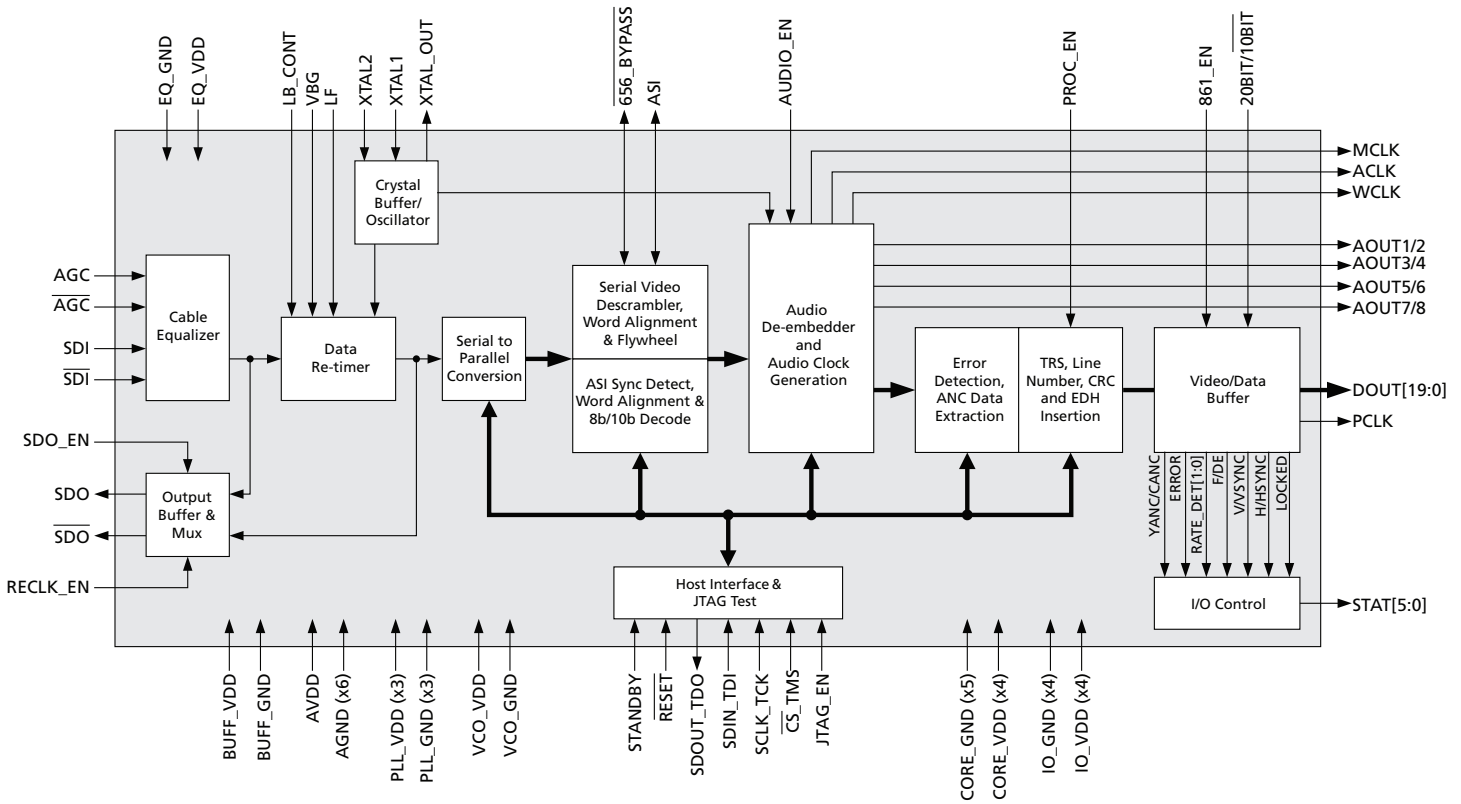

Figure A: GV7601 Block Diagram

	1	2	3	4	5	6	7	8	9	10
A	VBG	LF	LB_ CONT	VCO_ VDD	STAT0	STAT1	IO_VDD	PCLK	DOUT18	DOUT17
B	AVDD	PLL_ VDD	RSV	VCO_ GND	STAT2	STAT3	IO_GND	DOUT19	DOUT16	DOUT15
C	SDI	AGND	PLL_ VDD	PLL_ VDD	STAT4	STAT5	$\overline{\text{RESET}}$	DOUT12	DOUT14	DOUT13
D	$\overline{\text{SDI}}$	AGND	AGND	PLL_ GND	CORE_ GND	CORE_ VDD	RSV	JTAG_ EN	IO_GND	IO_VDD
E	EQ_ VDD	EQ_ GND	AGND	PLL_ GND	CORE_ GND	CORE_ VDD	SDOUT_ TDO	SDIN_ TDI	DOUT10	DOUT11
F	AGC	RSV	AGND	PLL_ GND	CORE_ GND	CORE_ VDD	$\overline{\text{CS}}$ TMS	SCLK_ TCK	DOUT8	DOUT9
G	$\overline{\text{AGC}}$	AGND	RECLK_ EN	CORE_ GND	CORE_ GND	CORE_ VDD	$\overline{\text{656}}$ BYPASS	ASI	IO_GND	IO_VDD
H	BUFF_ VDD	BUFF_ GND	AUDIO_ EN	WCLK	861_EN	XTAL_ OUT	20BIT/ 10BIT	PROC_ EN	DOUT6	DOUT7
J	SDO	SDO_EN	AOUT1/2	ACLK	AOUT5/6	XTAL2	IO_GND	DOUT1	DOUT4	DOUT5
K	$\overline{\text{SDO}}$	STAND BY	AOUT3/4	MCLK	AOUT7/8	XTAL1	IO_VDD	DOUT0	DOUT2	DOUT3

Figure B: GV7601 100-BGA Ball Placement

Aviia™ is Gennum's high bandwidth, all digital, long reach A/V interface for professional and industrial applications; providing high definition video, digital audio, bi-directional control and power over a single-wire robust and cost effective interface.

**DOCUMENT IDENTIFICATION
PRODUCT BRIEF**

The product is in a development phase and specifications are subject to change without notice. Gennum reserves the right to remove the product at any time. Listing the product does not constitute an offer for sale.

CAUTION

ELECTROSTATIC SENSITIVE DEVICES
DO NOT OPEN PACKAGES OR HANDLE EXCEPT AT A
STATIC-FREE WORKSTATION



GENNUM CORPORATE HEADQUARTERS

4281 Harvester Road, Burlington, Ontario L7L 5M4 Canada

Phone: +1 (905) 632-2996

E-mail: corporate@gennum.com

Fax: +1 (905) 632-2055

www.gennum.com

OTTAWA

232 Herzberg Road, Suite 101
Kanata, Ontario K2K 2A1
Canada

Phone: +1 (613) 270-0458

Fax: +1 (613) 270-0429

CALGARY

3553 - 31st St. N.W., Suite 210
Calgary, Alberta T2L 2K7
Canada

Phone: +1 (403) 284-2672

UNITED KINGDOM

North Building, Walden Court
Parsonage Lane,
Bishop's Stortford Hertfordshire, CM23 5DB
United Kingdom

Phone: +44 1279 714170

Fax: +44 1279 714171

INDIA

#208(A), Nirmala Plaza,
Airport Road, Forest Park Square
Bhubaneswar 751009
India

Phone: +91 (674) 653-4815

Fax: +91 (674) 259-5733

SNOWBUSH IP - A DIVISION OF GENNUM

439 University Ave. Suite 1700
Toronto, Ontario M5G 1Y8
Canada

Phone: +1 (416) 925-5643

Fax: +1 (416) 925-0581

E-mail: sales@snowbush.com

Web Site: <http://www.snowbush.com>

MEXICO

288-A Paseo de Maravillas
Jesus Ma., Aguascalientes
Mexico 20900

Phone: +1 (416) 848-0328

JAPAN KK

Shinjuku Green Tower Building 27F
6-14-1, Nishi Shinjuku
Shinjuku-ku, Tokyo, 160-0023
Japan

Phone: +81 (03) 3349-5501

Fax: +81 (03) 3349-5505

E-mail: gennum-japan@gennum.com

Web Site: <http://www.gennum.co.jp>

TAIWAN

6F-4, No.51, Sec.2, Keelung Rd.
Sinyi District, Taipei City 11502
Taiwan R.O.C.

Phone: (886) 2-8732-8879

Fax: (886) 2-8732-8870

E-mail: gennum-taiwan@gennum.com

GERMANY

Hainbuchenstraße 2
80935 Muenchen (Munich), Germany

Phone: +49-89-35831696

Fax: +49-89-35804653

E-mail: gennum-germany@gennum.com

NORTH AMERICA WESTERN REGION

Bayshore Plaza
2107 N 1st Street, Suite #300
San Jose, CA 95131
United States

Phone: +1 (408) 392-9454

Fax: +1 (408) 392-9427

E-mail: naw_sales@gennum.com

NORTH AMERICA EASTERN REGION

4281 Harvester Road
Burlington, Ontario L7L 5M4
Canada

Phone: +1 (905) 632-2996

Fax: +1 (905) 632-2055

E-mail: nae_sales@gennum.com

KOREA

8F Jinnex Lakeview Bldg.
65-2, Bangidong, Songpagu
Seoul, Korea 138-828

Phone: +82-2-414-2991

Fax: +82-2-414-2998

E-mail: gennum-korea@gennum.com

Gennum Corporation assumes no liability for any errors or omissions in this document, or for the use of the circuits or devices described herein. The sale of the circuit or device described herein does not imply any patent license, and Gennum makes no representation that the circuit or device is free from patent infringement.

All other trademarks mentioned are the properties of their respective owners.

GENNUM, the Gennum logo and Aviia are trademarks or registered trademarks of Gennum Corporation.

© Copyright 2009 Gennum Corporation. All rights reserved.

www.gennum.com