



GS2961 3Gb/s, HD, SD SDI Receiver, with Integrated Adaptive Cable Equalizer

Key Features

- Operation at 2.97Gb/s, 2.97/1.001Gb/s, 1.485Gb/s, 1.485/1.001Gb/s and 270Mb/s
- Supports SMPTE 425M (Level A and Level B), SMPTE 424M, SMPTE 292M, SMPTE 259M-C and DVB-ASI
- Integrated adaptive cable equalizer
- Typical equalized length of Belden 1694A cable:
 - ♦ 150m at 2.97Gb/s
 - ♦ 250m at 1.485Gb/s
 - ♦ 480m at 270Mb/s
- Integrated Reclocker with low phase noise, integrated VCO
- Serial digital reclocked, or non-reclocked output
- Ancillary data extraction
- Optional conversion from SMPTE 425M Level B to Level A for 1080p 50/60 4:2:2 10-bit
- Parallel data bus selectable as either 20-bit or 10-bit
- Comprehensive error detection and correction features
- Output H, V, F or CEA 861 Timing Signals
- 1.2V digital core power supply, 1.2V and 3.3V analog power supplies, and selectable 1.8V or 3.3V I/O power supply
- GSPI Host Interface
- -20°C to +85°C operating temperature range
- Low power operation (typically 515mW)
- Small 11mm x 11mm 100-ball BGA package
- Pb-free and ROHS compliant

Applications

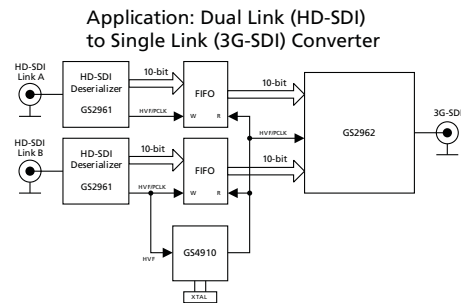
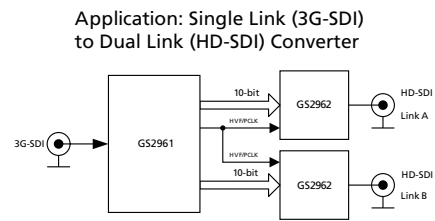

Description

The GS2961 is a multi-rate SDI integrated Receiver which includes complete SMPTE processing, as per SMPTE 425M, 292M and SMPTE 259M-C. The SMPTE processing features can be bypassed to support signals with other coding schemes.

The GS2961 integrates Gennum's next-generation state-of-the-art adaptive cable equalizer technology, achieving unprecedented cable lengths and jitter tolerance. It features DC restoration to compensate for the DC content of SMPTE pathological signals.

The device features an Integrated Reclocker with an internal VCO and a wide Input Jitter Tolerance (IJT) of 0.7UI.

A serial digital loop through output is provided, which can be configured to output either relocked or non-relocked serial digital data. The Serial Digital Output can be connected to an external Cable Driver.

The device operates in one of four basic modes: SMPTE mode, DVB-ASI mode, Data-Through mode or Standby mode.

In SMPTE mode, the GS2961 performs SMPTE de-scrambling and NRZI to NRZ decoding and word alignment. Line-based CRC errors, line number errors, TRS errors and ancillary data check sum errors can all be detected. The GS2961 also provides ancillary data extraction. The entire ancillary data packet is extracted, and written to host-accessible registers. Other processing functions include H:V:F timing extraction, Luma and Chroma ancillary data indication, video standard detection, and SMPTE 352M packet detection and decoding. All of the processing features are optional, and may be enabled or disabled via the Host Interface.

Both SMPTE 425M Level A and Level B inputs are supported. The GS2961 also provides user-selectable conversion from Level B to Level A for 1080p 50/60 4:2:2 10-bit formats only.

In DVB-ASI mode, 8b/10b decoding is applied to the received data stream.

In Data-Through mode, all forms of SMPTE and DVB-ASI decoding are disabled, and the device can be used as a simple serial to parallel converter.

The device can also be placed in a lower power Standby mode. In this mode, no signal processing is carried out and the parallel output is held static. Placing the Receiver in Standby mode will automatically place the integrated equalizer in power down mode as well.

Parallel data outputs are provided in 20-bit or 10-bit multiplexed format for 3Gb/s, HD and SD video rates. For 1080p 50/60 4:2:2 10-bit, the parallel data is output on the 20-bit parallel bus as Y on 10 bits and Cb/Cr on the other 10 bits. As such, this parallel bus can interface directly with video processor ICs. For other SMPTE 425M mapping structures, the video data is mapped to a 20-bit virtual interface as described in SMPTE 425M. In all cases this 20-bit parallel bus can be multiplexed onto 10 bits for a low pin count interface with downstream devices. The associated Parallel Clock input signal operates at 148.5 or 148.5/1.001MHz (for all 3Gb/s HD 10-bit multiplexed modes), 74.25 or 74.25/1.001MHz (for HD 20-bit mode), 27MHz (for SD 10-bit mode) and 13.5MHz (for SD 20-bit mode).

Note: for 3Gb/s 10-bit mode the device operates in Dual Data Rate (DDR) mode, where the data is sampled at both

Functional Block Diagram

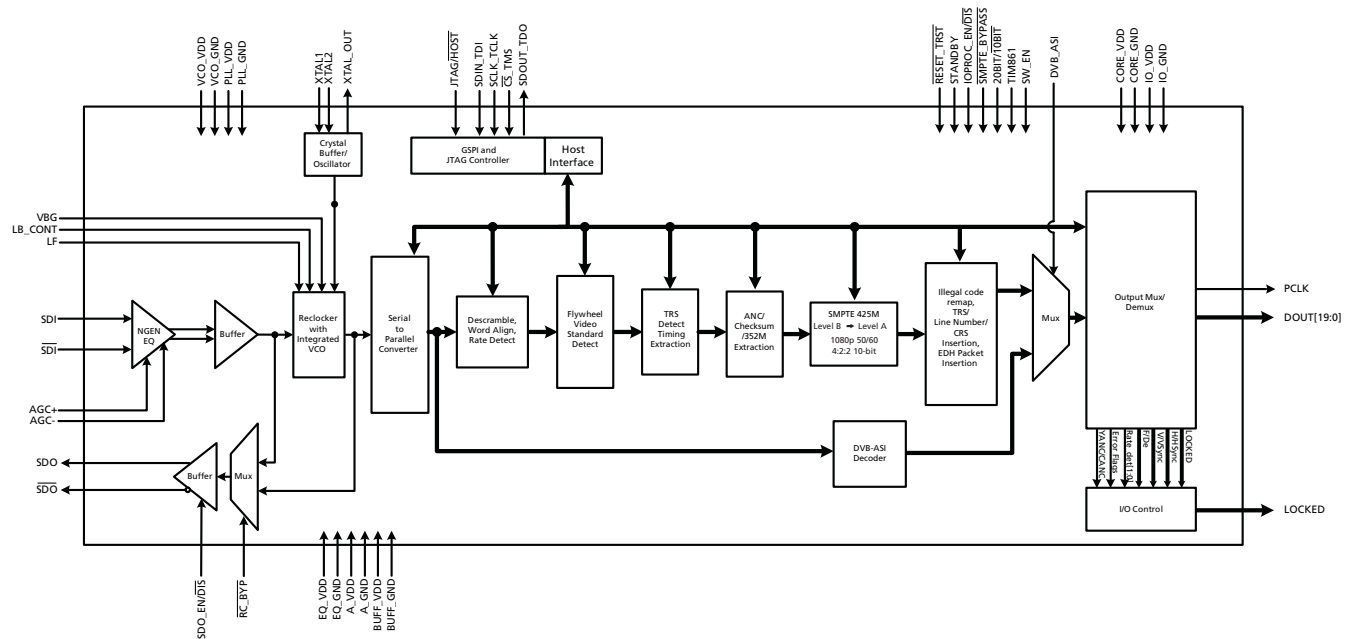

GS2961 Functional Block Diagram

Pin Out

	1	2	3	4	5	6	7	8	9	10
A	VBG	LF	LB_CONT	VCO_VDD	STAT0	STAT1	IO_VDD	PCLK	DOUT18	DOUT17
B	A_VDD	PLL_VDD	RSV	VCO_GND	STAT2	STAT3	IO_GND	DOUT19	DOUT16	DOUT15
C	SDI	A_GND	PLL_VDD	PLL_VDD	STAT4	STAT5	RESET_TRST	DOUT12	DOUT14	DOUT13
D	$\overline{\text{SDI}}$	A_GND	A_GND	PLL_GND	CORE_GND	CORE_VDD	SW_EN	JTAG_HOST	IO_GND	IO_VDD
E	EQ_VDD	EQ_GND	A_GND	PLL_GND	CORE_GND	CORE_VDD	SDOUT_TDO	SDIN_TDI	DOUT10	DOUT11
F	AGC+	RSV	A_GND	PLL_GND	CORE_GND	CORE_VDD	$\overline{\text{CS}}$ _TMS	SCLK_TCK	DOUT8	DOUT9
G	AGC-	A_GND	$\overline{\text{RC_BYP}}$	CORE_GND	CORE_GND	CORE_VDD	$\overline{\text{SMPTE}}$ _BYPASS	DVB_ASI	IO_GND	IO_VDD
H	BUFF_VDD	BUFF_GND	CORE_GND	RSV	TIM_861	XTAL_OUT	20bit/10bit	IOPROC_EN/DIS	DOUT6	DOUT7
J	SDO	SDO_EN/DIS	RSV	RSV	RSV	XTAL2	IO_GND	DOUT1	DOUT4	DOUT5
K	$\overline{\text{SDO}}$	STANDBY	RSV	RSV	RSV	XTAL1	IO_VDD	DOUT0	DOUT2	DOUT3

GS2961 Pin Out

The following table shows the pin difference between the GS2960 and the GS2961:

Pin Number	GS2960	GS2961	Functional Description of the GS2961 Pins
E1	SDI_VDD	EQ_VDD	POWER pin for the EQ.
E2	SDI_GND	EQ_GND	GND pin for the EQ.
F1	TERM	AGC+	Attach the AGC capacitor between this pin and AGC-.
G1	RSV	AGC-	Attach the AGC capacitor between this pin and AGC+.
G2	RSV	A_GND	Level adjust for the Equalizer.
G4	RSV	CORE_GND	GND connection – digital logic.
H3	RSV	CORE_GND	GND connection – digital logic.

**DOCUMENT IDENTIFICATION
PRODUCT BRIEF**

The product is in a development phase and specifications are subject to change without notice. Gennum reserves the right to remove the product at any time. Listing the product does not constitute an offer for sale.

CAUTION

ELECTROSTATIC SENSITIVE DEVICES
DO NOT OPEN PACKAGES OR HANDLE EXCEPT AT A
STATIC-FREE WORKSTATION



GENNUM CORPORATE HEADQUARTERS

4281 Harvester Road, Burlington, Ontario L7L 5M4 Canada

Phone: +1 (905) 632-2996

E-mail: corporate@gennum.com

Fax: +1 (905) 632-2055

www.gennum.com

OTTAWA

232 Herzberg Road, Suite 101
Kanata, Ontario K2K 2A1
Canada

Phone: +1 (613) 270-0458

Fax: +1 (613) 270-0429

CALGARY

3553 - 31st St. N.W., Suite 210
Calgary, Alberta T2L 2K7
Canada

Phone: +1 (403) 284-2672

UNITED KINGDOM

North Building, Walden Court
Parsonage Lane,
Bishop's Stortford Hertfordshire, CM23 5DB
United Kingdom

Phone: +44 1279 714170

Fax: +44 1279 714171

INDIA

#208(A), Nirmala Plaza,
Airport Road, Forest Park Square
Bhubaneswar 751009
India

Phone: +91 (674) 653-4815

Fax: +91 (674) 259-5733

SNOWBUSH IP - A DIVISION OF GENNUM

439 University Ave. Suite 1700
Toronto, Ontario M5G 1Y8
Canada

Phone: +1 (416) 925-5643

Fax: +1 (416) 925-0581

E-mail: sales@snowbush.com

Web Site: <http://www.snowbush.com>

MEXICO

288-A Paseo de Maravillas
Jesus Ma., Aguascalientes
Mexico 20900

Phone: +1 (416) 848-0328

JAPAN KK

Shinjuku Green Tower Building 27F
6-14-1, Nishi Shinjuku
Shinjuku-ku, Tokyo, 160-0023
Japan

Phone: +81 (03) 3349-5501

Fax: +81 (03) 3349-5505

E-mail: gennum-japan@gennum.com

Web Site: <http://www.gennum.co.jp>

TAIWAN

6F-4, No.51, Sec.2, Keelung Rd.
Sinyi District, Taipei City 11502
Taiwan R.O.C.

Phone: (886) 2-8732-8879

Fax: (886) 2-8732-8870

E-mail: gennum-taiwan@gennum.com

GERMANY

Hainbuchenstraße 2
80935 Muenchen (Munich), Germany

Phone: +49-89-35831696

Fax: +49-89-35804653

E-mail: gennum-germany@gennum.com

NORTH AMERICA WESTERN REGION

Bayshore Plaza
2107 N 1st Street, Suite #300
San Jose, CA 95131
United States

Phone: +1 (408) 392-9454

Fax: +1 (408) 392-9427

E-mail: naw_sales@gennum.com

NORTH AMERICA EASTERN REGION

4281 Harvester Road
Burlington, Ontario L7L 5M4
Canada

Phone: +1 (905) 632-2996

Fax: +1 (905) 632-2055

E-mail: nae_sales@gennum.com

KOREA

8F Jinnex Lakeview Bldg.
65-2, Bangidong, Songpagu
Seoul, Korea 138-828

Phone: +82-2-414-2991

Fax: +82-2-414-2998

E-mail: gennum-korea@gennum.com

Gennum Corporation assumes no liability for any errors or omissions in this document, or for the use of the circuits or devices described herein. The sale of the circuit or device described herein does not imply any patent license, and Gennum makes no representation that the circuit or device is free from patent infringement.

All other trademarks mentioned are the properties of their respective owners.

GENNUM and the Gennum logo are registered trademarks of Gennum Corporation.

© Copyright 2009 Gennum Corporation. All rights reserved.

www.gennum.com